

## PCTA 2100 & 2300

### AUTOMATIC ROTARY TURNTABLE



AUTOMATIC ROTARY  
TURNTABLE PCTA-2300



AUTOMATIC ROTARY  
TURNTABLE PCTA-2100

[www.phoenixwrappers.com](http://www.phoenixwrappers.com)



SEMI-AUTO TURNTABLE  
STRETCH WRAPPERS



ROTARY ARM STRETCH  
WRAPPERS



CUSTOM  
AUTOMATED SYSTEMS



HIGH SPEED AUTOMATED  
STRETCH WRAPPERS



FULLY INTEGRATED  
PACKAGING LINES

# PCTA 2100 & 2300

## AUTOMATIC ROTARY TURNTABLE



### TOUCHSCREEN CONTROLS

The PCTA 2100 and PCTA 2003 comes complete with an Allen Bradley PLC & Operator Touch Screen.

#### Including:

Nema 12 Control Enclosure 24 V Control System.

Separate Carriage Up/Down Speed Control.

Autoheight Photo-Eye for Variable Load Height detection.

Film Force to Load (Tension) Control.



### RING BEARING DRIVEN

This precision ground bearing support is the same principal that is used for army tanks, cranes, and foundry equipment. Where large oversized structures need to be supported in extreme harsh environments.

Although the use of such a bearing in a light application like a stretch wrapper is extreme over-engineering, it provides a clean bullet proof solution to the weight support and rotation of our table.



### PRESTRETCH CARRIAGE

A solid design concept both mechanically and electrically for a durable, dependable powered prestretch film carriage with added operator safety in mind!

The Phoenix film carriage design allows for the fastest and safest roll change in the industry.

Simply open carriage gate, lay the film on the gate, and close the gate. **IT'S THAT SIMPLE !**



### CUT & WIPE SYSTEM

The pneumatic controlled cut & wipe system automatically cuts the film and applies the film tail to the load. A timed impulse heat system, cold to the touch in seconds offers a safe cutting system.

Pneumatic driven clamp holds the film tail during rotation. The clamp release the film tail at the end of the cycle and once the table stops, the film clamp is activated to close and hold the film for the cutting process.

## NOTHING BEATS THE BEST IN CLASS!

### FLEXIBLE:

Meets most Stretch Wrapping Applications and is customized to meet your exact requirements.

### FAST:

Up to 15 RPM stretch wrapping speed. Fastest in its Class.

### REDUCED FILM USAGE:

Simple yet powerful controls provides flexibility and film savings. Separate 1-9 top and bottom wrap count provides up to 15% Savings.

### SUPERIOR STANDARD FEATURES:

Best in Class Wrapping Flexibility with Touchscreen Control provides all features as standard.... **Including those not available (or an upcharge) on competitive models.**

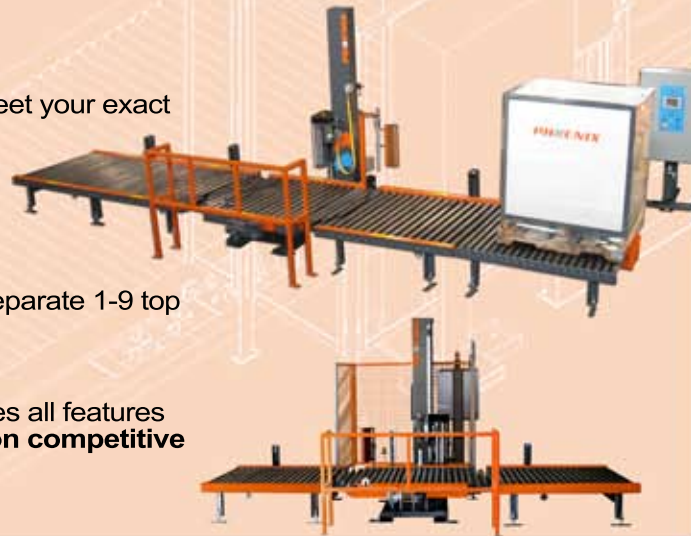

### GENERAL SPECIFICATIONS

<b>Load Size</b>	50" x 50"
<b>Load Weight</b>	4000 lbs.
<b>Load Height</b>	80"
<b>Power Req.</b>	230 Vac. 20 Amp

### Controls

<b>Up/Down Speeds carriage</b>	Separate
<b>Top &amp; Bottom Wrap Counters</b>	Separate 1-9 count
<b>Motor Controls</b>	Variable Frequency Drives

### Warranty

3 years-All Parts / 10 years-Frame  
Lifetime warranty on Pre-stretch Rollers

### Machine

	PCTA-2100	PCTA-2300
<b>Speed</b> (variable)	12 RPM	15 RPM
<b>Load Weight</b>	4000 Lbs.	4000 Lbs.
<b>Max Load Size</b>	50"x50"	50"x50"
<b>Production Cap.</b>	35-50/hr.	50-75/hr.

\*Specifications subject to change without notice

Phoenix...**Best in Class** performance  
at a **Best in Class** price!

[www.phoenixwrappers.com](http://www.phoenixwrappers.com)

Get the Facts and Compare!

(514) 956-1525



The Stretch Wrapping Experts

## PHOENIX PCTA 2100 AUTOMATIC ROTARY TURNTABLE MACHINE SPECIFICATIONS

### PERFORMANCE

Production Speed	Up to 35 pallets per hour
Maximum Load Size	50" x 50" x 80" load size (71" Diagonal)
Maximum Load Weight	4000 lbs (1814 kg)

### LOAD HANDLING

Wrapping Speed (Variable)	12 RPM
---------------------------	--------

### SERVICE REQUIREMENTS

Electric Service Requirements	208- 240 VAC / 3 PH / 60 HZ
Pneumatic Requirements	3 CFM @80 PSI

### WARRANTY

3 Year Warranty  
Lifetime warranty on the pre-stretch compound carriage rollers

### The Phoenix PCTA Series Advantage

The PCTA rotary turntable stretch wrapper systems offer a flexible and economical stretch wrapping of all pallet types. With its compact footprint this is the series of choice in most tight fitting stretch wrapping applications. Meets most stretch wrapping applications and is customized to meet your exact requirements. Designed to be a durable dependable machine that will, day in and day out, tackle all your toughest applications, while providing the maximum in customer flexibility in case your requirements change.

Please visit [www.phoenixwrappers.com](http://www.phoenixwrappers.com) for more detailed information about this machine model and all its available options.

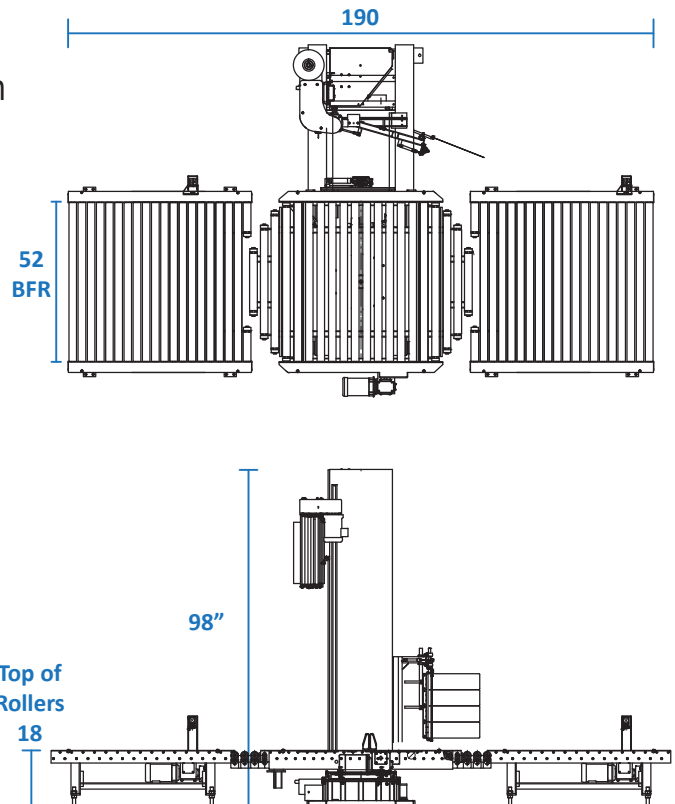

For more information call (514) 956-1525 or visit us at [www.phoenixwrappers.com](http://www.phoenixwrappers.com)



The Stretch Wrapping Experts

## PHOENIX PCTA 2300 AUTOMATIC ROTARY TURNTABLE MACHINE SPECIFICATIONS

### PERFORMANCE

Production Speed	Up to 40-50 pallets per hour
Maximum Load Size	50" x 50" x 80" load size (71" Diagonal)
Maximum Load Weight	4000 lbs (1814 kg)

### LOAD HANDLING

Wrapping Speed (Variable)	15 RPM
---------------------------	--------

### SERVICE REQUIREMENTS

Electric Service Requirements	208-240 VAC / 3PH / 60 HZ
Pneumatic Requirements	3 CFM @80 PSI

### WARRANTY

3 Year Warranty  
Lifetime warranty on the pre-stretch compound carriage rollers

### The Phoenix PCTA Series Advantage

The PCTA rotary turntable stretch wrapper systems offer a flexible and economical stretch wrapping of all pallet types. With its compact footprint this is the series of choice in most tight fitting stretch wrapping applications. Meets most stretch wrapping applications and is customized to meet your exact requirements. Designed to be a durable dependable machine that will, day in and day out, tackle all your toughest applications, while providing the maximum in customer flexibility in case your requirements change.

Please visit [www.phoenixwrappers.com](http://www.phoenixwrappers.com) for more detailed information about this machine model and all its available options.

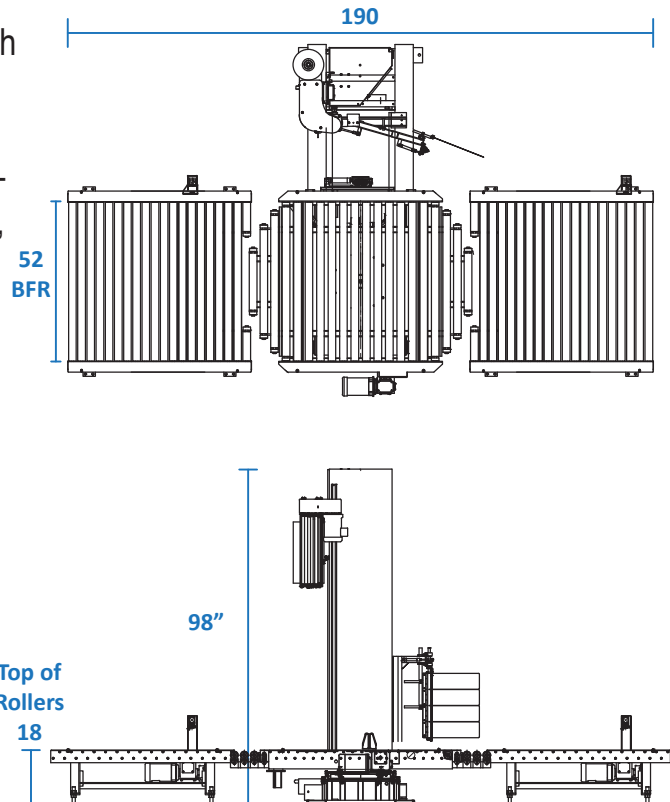

For more information call (514) 956-1525 or visit us at [www.phoenixwrappers.com](http://www.phoenixwrappers.com)