



**A-B-C PACKAGING  
MACHINE CORPORATION**



CASE SEALING



A true production case sealer with an ultra compact footprint- just 8' long  
Hot melt sealing model

## Model 236 Top Case Sealer

When you need a compact case sealer for your midrange sealing requirements, consider the Model 236- the small case sealer that gives you more.

- Non-stop case feed for reliable, high speed sealing
- Packed with quality production features
- Built to provide years of carefree service and quick change versatility for future requirements

# Rugged and reliable midrange top case sealer



Tape sealing model

## Quality features for a better machine:

- Steel frame construction
- Metering roller infeed automatically feeds cases spaced or back to back
- Rotating flap tucker folds trailing inner flap
- Contoured cast aluminum flap folders fold outer flaps
- Flexible compression rollers provide secure adhesive seal
- Easy access tape head for quick replenishment
- Clear, high visibility guards - electrically interlocked to stop the machine when opened
- Substantial 1 hp drive motor powers case sealer
- Adjustable leveling footpads (+/- 2")
- Sealed bearings minimize maintenance
- Automatic water eliminator keeps air lines dry
- Quick changeover with rapid-adjust hand cranks

## A compact machine with a large case range

Case range:	L	W	H
RSC, CSSC cases	Min 8"	6"	4"
	Max 24"	16"	15"

## Specifications:

Electrical: Primary 230 or 460v, 60hz, 3ph, NEMA 12

Mechanical: 1 hp motor

Air: .08 cu. ft. per cycle at 60 psi

Speed: To 25 cases/minute

## 236HM hot melt sealing

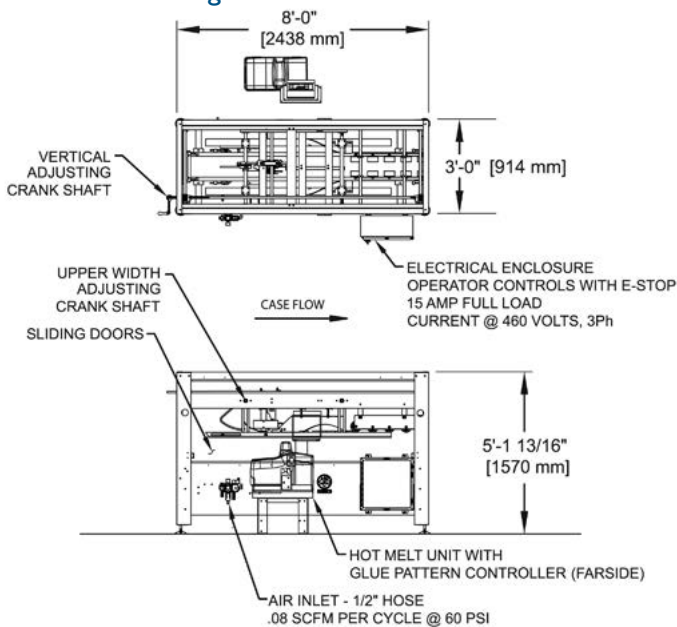

## 236T tape sealing

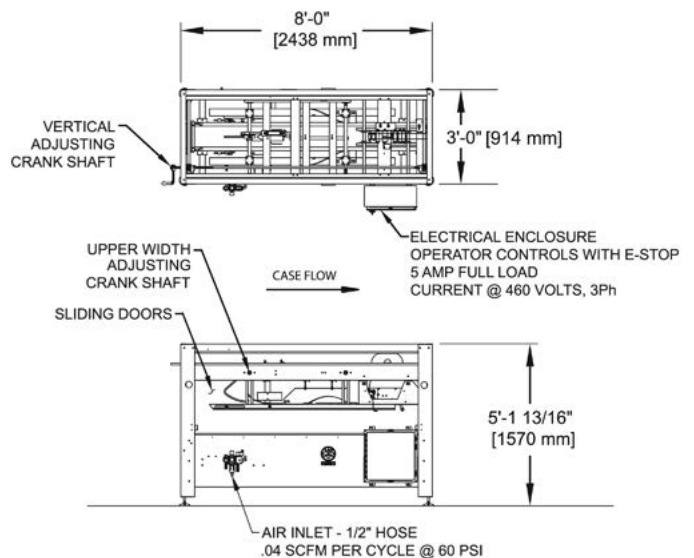

C-157-12/17

All information in this brochure was current at time of printing, however, in the continuing effort to improve the quality and construction of A-B-C equipment, we reserve the right to make changes without notice.



**A-B-C PACKAGING  
MACHINE CORPORATION**



ERECTORS



PACKERS



SEALERS



PARTITIONERS



PALLETIZERS



DEPALLETIZERS



DECASERS

811 Live Oak Street, Tarpon Springs, FL 34689 • 727-937-5144 • Fax 727-938-1239 • www.abcpackaging.com