

PHOENIX

PHPA-2200 & PLPA-2150 AUTOMATIC TURNTABLE STRETCH WRAPPING MACHINES



PHOENIX
LOW PROFILE
PLPA-2150



PHOENIX
HIGH PROFILE
PHPA-2200

www.phoenixwrappers.com



SEMI-AUTO TURNTABLE
STRETCH WRAPPERS



ROTARY ARM STRETCH
WRAPPERS



CUSTOM
AUTOMATED SYSTEMS



HIGH SPEED AUTOMATED
STRETCH WRAPPERS



FULLY INTEGRATED
PACKAGING LINES

PHPA-2200 & PLPA-2150

AUTOMATIC TURNTABLE STRETCH WRAPPING MACHINES



FILM COST SAVINGS

Multiple wrap cycles apply film only where required.

Separate up/down speeds save time & up to 10% reduction of stretch film costs.

Separate top/bottom wrap selections eliminate wasted revolutions of film.

Film saving logic eliminates film waste.



SAFETY MEASURES

Timed, impulse cut wire is only ON when cutting and cold to the touch in seconds.

Not hazardous to operator.

No permanent, constant heat source.

Pneumatic cut & wipe system with no mechanical drive thus, nothing gets caught in mechanical system.



MAINTENANCE WISE

More table support casters than any in its class.

Maintenance-free polymer support bearings for quiet, efficient operation.

Structural angle guard is welded to turntable to protect film clamp when un/loading.

Lifetime Warranty on Pre-stretch Rollers.



DURABLE DESIGN

Dual #50 chain carriage lifting system for unprecedented safety.

HSS formed steel tower to protect lifting & rotation motors.

Solid "cold rolled" steel carriage guide bars welded in the tower.

Top quality commercially available components.

Meets all Cdn & US standards with cUL Approval.

NOTHING BEATS THE BEST IN CLASS!

Auto Cut, Wipe & Film Tail Treatment:

Pneumatic system cuts (not tears), wipes, and brushes film to load...no film tail!

Heavier:

Built to last...the 5000 lbs. std. weight capacity is the heaviest in its class.

Faster:

At 15RPM, it's the fastest wrapping speed in its class. Wrap more loads...faster.

Ultimate Control:

Best in Class controls. Simple yet powerful controls offer wrap flexibility and film savings.



AUTO CUT & WIPE, HEAVIER & FASTER...BEST IN CLASS!

GENERAL SPECIFICATIONS

Wrapping Speed Variable up to 15RPM

Load Diagonal Max. 80"

Load Weight Max. 5000 lbs.

Load Height Up to 80"

Wrap Tension Variable

Power Requirement 120 Vac. 15 Amp

Controls

3 Wrap Programs

Up/Down Speeds carriage

Top & Bottom Wrap Counters

Control Settings

Wrap up & Wrap up/ Down

Top Cover Pause

Separate

Separate 1-9 count

Password Protected

Warranty

3 years-All Parts / 10 years-Frame

Lifetime warranty on Pre-stretch Rollers

Turntable

	PHPA-2200	PLPA-2150
Support Casters	9 H.D.	28 H.D.
Height	8" 3/4	2" 7/8
Size	48"x48" (octagon)	67" diameter
Forklift Portable	Front & Back	Front

*Specifications subject to change without notice

Phoenix...**Best in Class** performance
at a **Best in Class** price!

www.phoenixwrappers.com

Get the Facts and Compare!

(514) 956-1525



PHOENIX PLPA 2150 AUTOMATIC TURNTABLE

MACHINE SPECIFICATIONS

PERFORMANCE

Production Speed	Up to 40 pallets per hour
Maximum Load Size	52" x 52" x 80" load size (74" Diagonal)
Maximum Load Weight	5000 lbs (2267kg)

LOAD HANDLING

Turntable Speed (Variable)	15 RPM
Turntable Base	26x high capacity table support casters

SERVICE REQUIREMENTS

Electric Service Requirements	120 VAC / 1 PH / 60 HZ
Pneumatic Requirements	3 CFM @80 PSI

WARRANTY

5 Year Warranty
Lifetime warranty on the pre-stretch compound carriage rollers

The Phoenix 2150 Series Advantage

If you are looking for a portable, safe, reliable and easy to operate automatic low profile stretch wrapper, the PLPA-2150 is the best choice for your packaging application. While it can be used as a stationary wrapping station, the PLPA-2150 offers the flexibility of being **forklift portable from the front and the back**, so it can be easily moved around your warehouse where or when you need it. Operating the wrapper is very simple: The PLPA-2150 is a fully automatic stretch wrapper, so you just need to place the load on the table and pull the cord, the Phoenix PLPA-2150 wrapper will do the rest.

Please visit www.phoenixwrappers.com for more detailed information about this machine model and all its available options.

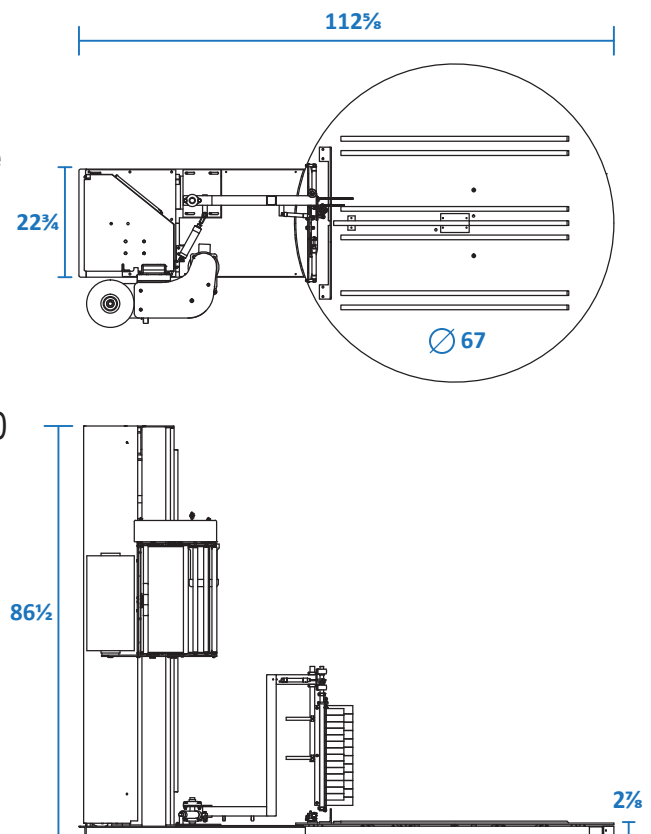

For more information call (514) 956-1525 or visit us at www.phoenixwrappers.com